

March 16, 2026

Upper Valley Waste Management Agency
c/o Napa County Public Works
Department 1195 Third St., Napa, CA
9455

Attention: Mr. Steve Lederer; Public Works Director

Via Email: Steven.Lederer@countyofnapa.org

Cc: upvalleyrecycles@countyofnapa.org

Re: **Upper Valley Waste Management Agency Grant Program;
Request for Grant Funds to Improve Access and Guidance for Waste Sorting and to Combat
the use of Single Use Plastics.**

Dear Mr. Lederer,

The Town of Yountville Public Works is seeking financial support to enhance trash disposal methods and decrease the use of single use plastics within public spaces. In the past, grant funds provided by the Upper Valley Waste Management Agency (UVWMA) facilitated the installation of "Big Belly" receptacles at two primary parks and the Community Center. The introduction of these receptacles has led to improvements in waste sorting practices in those areas. However, the current usage of Big Belly receptacles is limited in certain public parks due to specific restrictions. Notably, the receptacles must be capable of handling larger items, such as pizza boxes and large food containers, which is not always possible with the existing units. While the Big Belly receptacles are equipped with signage to guide proper waste sorting, contamination of recycling and compost bins still occur. The compacting mechanism of these receptacles often makes it challenging to remove contaminants from the recycling and compost streams once they are inside. Town staff are finding repeated cases of contamination in the recycling bins from the standard waste bins and the Big Belly style waste bins.

The Town's proposed solution is to acquire container enclosures that will incorporate the standard trash totes already used by residents provided by Upper Valley Waste. Because residents are already familiar with this style of tote, introducing them in public spaces will make it easier for everyone to properly sort trash, recycling, and compost. These new bins will be accompanied by improved signage to encourage proper sorting and help reduce contamination across all collection points.

After conducting a thorough evaluation of available waste receptacle models, the Town has identified a solution that aligns with the community's requirements. The Tivor brand trash enclosures offer a sophisticated and highly functional approach to waste management. Constructed from durable, weather-resistant wood, these enclosures are designed not only to enhance the organization and cleanliness of public spaces, but also to complement and elevate

the visual appeal of their surroundings. Each unit is meticulously crafted to integrate harmoniously with the landscape, thereby providing both practical utility and aesthetic value.

The plan is to buy 3 Tivor trash enclosures for the Coop (Farmstand), Town Hall back lot, and Yountville Commons Schmitt Hall. We'll assess their effectiveness at these sites before installing them in public parks. By doing so, the Town aims to make its waste diversion program as efficient and effective as possible.

In tandem with our ongoing waste management initiatives, the Town is also adopting a more proactive and comprehensive strategy to reduce the use of single-use plastics. At present, water filling stations are available within our public buildings, and they have proven both popular and effective in reducing disposable bottle usage. Building on this success, the Town conducted thorough research to select outdoor water filling station models that are both highly functional and visually appropriate for our parks and community spaces. By expanding access to these types of stations, we aim to further encourage residents and visitors alike to embrace reusable water containers, thereby fostering a culture of sustainability throughout Yountville.

This water filling station is designed to dispense both chilled still water and sparkling water to the public, featuring user-friendly button activation and automated timed dispensing. The first location for this type of water filling station will be at the Coop (Farmstand) behind town hall. This spot is easy to access and monitor, which will help us better track its usage and the benefits it brings to the community.

In summary the town is requesting a total of \$25,000 for the following improvements.

- | | |
|--|-----------------|
| 1. Trash Enclosure Tivor Brand Boxes at 3 locations | |
| a. Coop (Farmstand) located behind town hall. | \$2,680 |
| b. Town Hall trash area located in the back parking lot. | \$2,680 |
| c. Yville Commons Schmitt Hall site. | \$2,680 |
| 2. Signage and materials to encourage proper sorting | \$2,000 |
| 3. Outdoor Water Refill Station with still water and sparking water. | <u>\$10,078</u> |
| | Total: \$20,118 |

Attached are the quotes received from Tivor Box for the trash enclosures and Culligan Quench for the water fountain dispenser. The cost for educational materials is an estimate based on recent signage and material costs.

Thank you in advance for your consideration of this request. If you have any questions, or need more information please contact me at your convenience.

Sincerely,

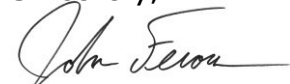

John Ferons
Public Works Director

Water Filling Station Freestanding (576)	Purchase	Install	3 YR Annual MC (Avg)
Top Pro (FS)	\$7,440	\$800	\$1,628
Top Pro (Mechanical Buttons) FS	\$7,650	\$800	\$1,628



Product Details

Enhance your workplace hydration solutions with some sparkle! The 576: Vivreau® Top Pro offers sparkling and semi-sparkling water as well as still cold and ambient drinking water through an intuitive push button or touch dispensing interface. This compact, eye-catching sparkling water dispenser fits in the most modern breakrooms or hygiene-sensitive environments, like hospitals, healthcare facilities, and wellness and spas. The 576 offers innovative installation with an optional easy access control panel that can be positioned and installed at different heights for universal access. The 576: Vivreau® Top Pro is available as a freestanding or countertop machine.

Vivreau® Top Pro

- Cold and ambient filtered still water
- Chilled sparkling and semi-sparkling water
- Intuitive touch or mechanical button dispensing with preset portions
- Large 13" dispensing area and drip tray
- Aluminum dry block cooling technology
- Advanced filtration for clean, great-tasting filtered water
- Taller, ergonomic design for easy, no-bend dispensing (Freestanding)
- Available as a freestanding or countertop machine

Culligan Quench products are certified by independent authorized 3rd party laboratories in accordance of appropriate industry standards. To find out more about which certification your product may have, please contact us.

All sparkling water dispensers require CO₂ cylinders. If connecting to a bulk or existing CO₂ system, a CO₂ line terminating at a 1/4" barbed shut-off valve must be available at the installation site.

© 2025 Culligan Quench. All rights reserved. 576-001-AUG25

Specifications

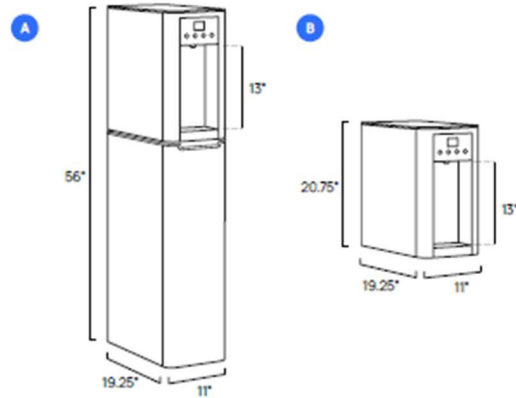

A 576 Freestanding

Dimensions	56" h x 11" w x 19.25" d
Dispensing Area	13"
Weight	138 lbs
Water Options	Cold still, ambient still, chilled sparkling, chilled semi-sparkling
Continuous Cold Water Supply	22.4 gal/hr (84.8 liters/hr)
Cooling Technology	Ice bank cooling technology
Recommended Water Pressure	50 - 80 PSI
Rated Voltage/Frequency	60 Hz/120 V
Power Consumption	8 amps
Model	576 FS VC T / 576 FS VC M

B 576 Countertop

Dimensions	20.75" h x 11" w x 19.25" d
Dispensing Area	13"
Weight	88 lbs
Water Options	Cold still, ambient still, chilled sparkling, chilled semi-sparkling
Continuous Cold Water Supply	22.4 gal/hr (84.8 liters/hr)
Cooling Technology	Ice bank cooling technology
Recommended Water Pressure	50 - 80 PSI
Rated Voltage/Frequency	60 Hz/120 V
Power Consumption	8 amps
Model	576 CT VC T / 576 CT VC M

Tivor Box Trash Enclosure

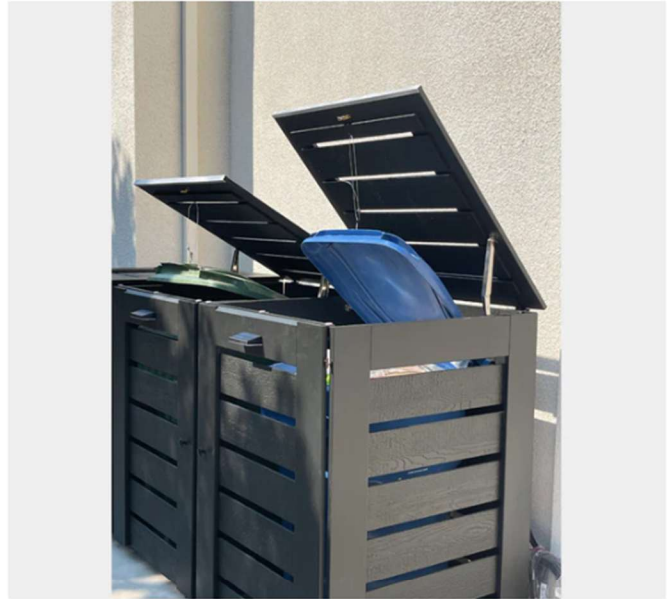

PVC / Box for 3 bins

\$2,680.00 USD

Shipping calculated at checkout.

From \$241.89/mo with [shop by](#) [Check your purchasing power](#)

Color: Custom



Installation Available: Each box comes with a step-by-step instruction manual for easy self-assembly. If you'd like help with installation, we also provide professional service throughout California and will contact you with a installation quote.

I'll Do It Myself

Add Installation

Quantity

- 1 +